

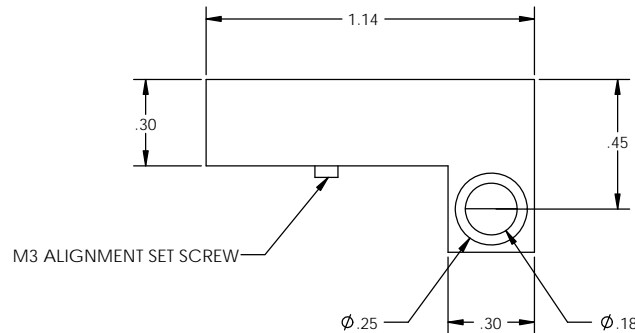

2X 1.125" C-SEAL INTERFACE

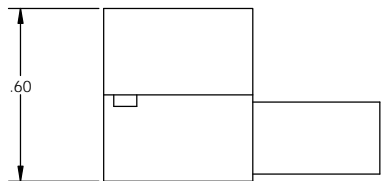

M3 ALIGNMENT SET SCREW

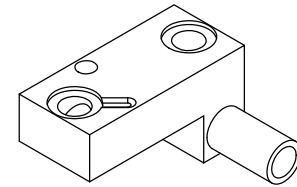
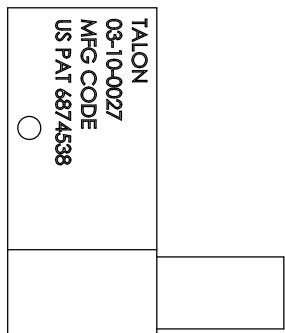

- NOTES:
1. DRAWINGS FOR SPECIFICATION PURPOSES AND ARE FOR REFERENCE ONLY.
  2. ALL VERSIONS OF THE DRAWING ARE SUPERSEDED BY THIS RELEASE AND SUBJECT TO CHANGE WITHOUT NOTIFICATION.
  3. MATERIAL: 316L SST, SEMI F20.
  4. INTERNAL FINISHES: MACHINED AND ELECTROPOLISHED TO 5 Ra MAX.

EFFECTIVE DATE: 2/6/2017		 INNOVATION WITH PRECISION 1003 INDUSTRIAL DRIVE SAUK RAPIDS, MN 56379 VOICE: 320-251-0390 FAX: 320-251-5810	
INTERPRET DRAWING PER: ASME Y14.5 - 2009			
THIRD ANGLE PROJECTION 			
PROPRIETARY AND CONFIDENTIAL THE INFORMATION CONTAINED IN THIS DRAWING IS THE SOLE PROPERTY OF TALON INNOVATIONS, INC. ANY REPRODUCTION IN PART OR AS A WHOLE WITHOUT THE WRITTEN PERMISSION OF TALON INNOVATIONS, INC. IS PROHIBITED.		DESCRIPTION: <b>TMS 1.125" C-SEAL INSERT,          BRANCH MANIFOLD RIGHT</b>	
SIZE <b>C</b>	PART NUMBER: <b>03-10-0027</b>		
DO NOT SCALE DRAWING		SCALE: 3:1	SHEET 1 OF 1