

8

7

6

5

4

3

2

1

F

E

D

C

B

A

F

E

D

C

B

A

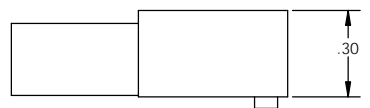
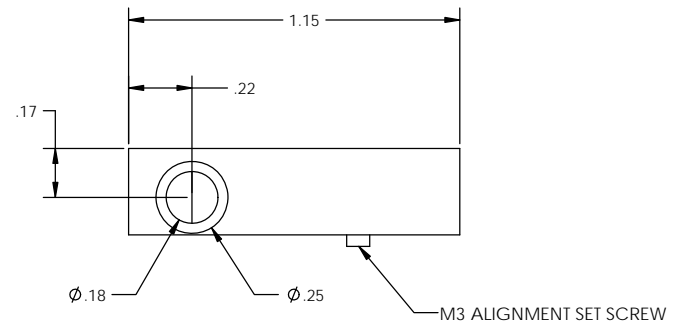
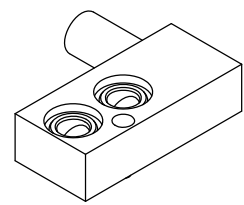
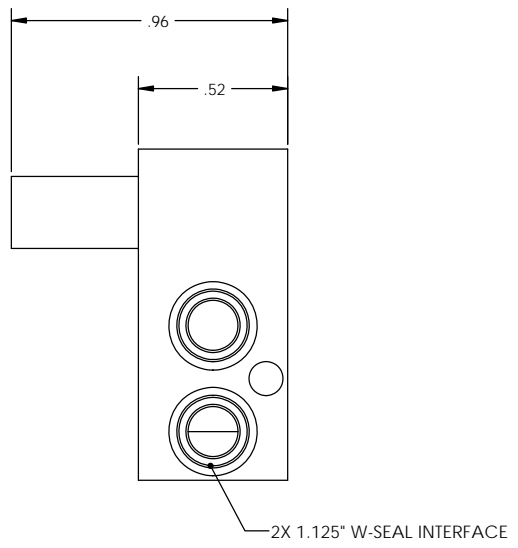

- NOTES:
1. DRAWINGS FOR SPECIFICATION PURPOSES AND ARE FOR REFERENCE ONLY.
  2. ALL VERSIONS OF THE DRAWING ARE SUPERSEDED BY THIS RELEASE AND SUBJECT TO CHANGE WITHOUT NOTIFICATION.
  3. MATERIAL: 316L SST, SEMI F20.
  4. INTERNAL FINISHES: MACHINED AND ELECTROPOLISHED TO 5 Ra MAX.

|                                                                                                                                                                                                                                                             |                                   |                                                                                                                    |                                                                                            |
|-------------------------------------------------------------------------------------------------------------------------------------------------------------------------------------------------------------------------------------------------------------|-----------------------------------|--------------------------------------------------------------------------------------------------------------------|--------------------------------------------------------------------------------------------|
| EFFECTIVE DATE:<br>2/6/2017                                                                                                                                                                                                                                 |                                   | <br>INNOVATION WITH PRECISION | 1003 INDUSTRIAL DRIVE<br>SAUK RAPIDS, MN 56379<br>VOICE: 320-251-0390<br>FAX: 320-251-5810 |
| INTERPRET DRAWING PER:<br>ASME Y14.5 - 2009<br>THIRD ANGLE PROJECTION                                                                                                                                                                                       |                                   |                                                                                                                    |                                                                                            |
| PROPRIETARY AND CONFIDENTIAL<br>THE INFORMATION CONTAINED IN THIS<br>DRAWING IS THE SOLE PROPERTY OF<br>TALON INNOVATIONS, INC. ANY<br>REPRODUCTION IN PART OR AS A WHOLE<br>WITHOUT THE WRITTEN PERMISSION OF<br>TALON INNOVATIONS, INC. IS<br>PROHIBITED. |                                   | DESCRIPTION:<br><b>TMS 1.125" W-SEAL INSERT,<br/>         BRANCH MANIFOLD LEFT</b>                                 |                                                                                            |
| SIZE<br><b>C</b>                                                                                                                                                                                                                                            | PART NUMBER:<br><b>03-10-0041</b> |                                                                                                                    | SHEET 1 OF 1                                                                               |
| DO NOT SCALE DRAWING                                                                                                                                                                                                                                        |                                   | SCALE: 3:1                                                                                                         |                                                                                            |

8

7

6

5

4

3

2

1