

4.74  
.44 TYP.  
OUTLET  
INLET  
FEMALE FACE SEAL, SWIVEL  
A PORT CONFIGURATION  
TALON  
MFG CODE

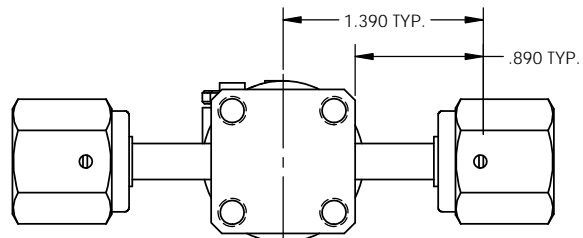

FEMALE FACE SEAL, SWIVEL

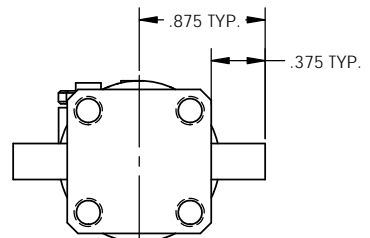

TUBE STUB

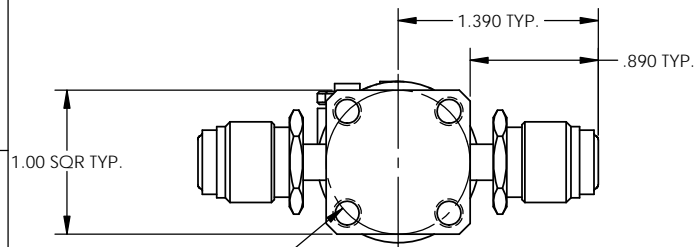

4X M5 X 0.8  
EQ SPACE  
ON Ø1.00  
MALE FACE SEAL, SWIVEL

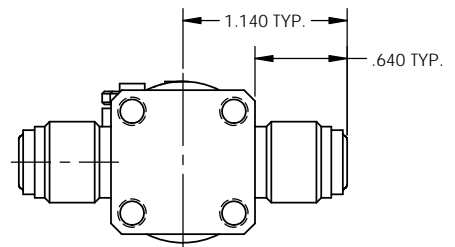

MALE FACE SEAL

ORDERING NUMBER

CDV 4 X - XX XX XX XX - 07 X X X

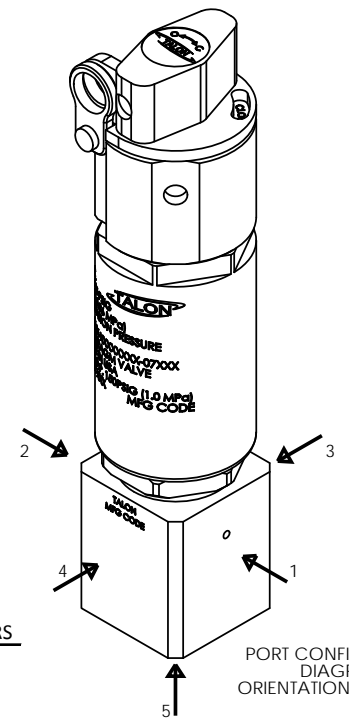
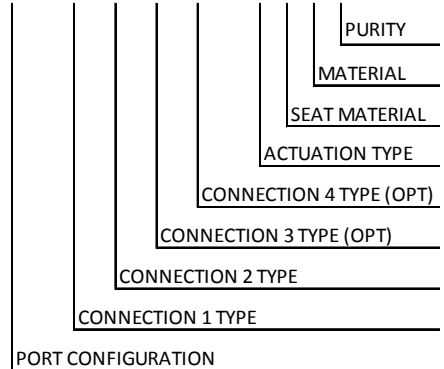

PORT CONFIGURATION DIAGRAM  
ORIENTATION AS SHOWN

PORT CONFIGURATION DESIGNATORS  
(INLETS - OUTLETS)

- A = 2-PORT VALVE (1-2)
- B = 2-PORT VALVE (3-1)
- C = 3-PORT VALVE (3-1/3)
- D = 3-PORT VALVE (2-1/3)
- E = 3-PORT VALVE (1-2/3)
- F = 3-PORT VALVE (1/2-3)
- G = 3-PORT VALVE (1/3-2)
- H = 3-PORT VALVE (2/3-1)
- I = 4-PORT VALVE (1/3/4-2)
- J = 4-PORT VALVE (1-2/3/4)
- K = 4-PORT VALVE (1/2-3/4)
- L = 4-PORT VALVE (1/4-2/3)
- M = 2-PORT VALVE (5-1)
- N = 2-PORT VALVE (1-3)

SEAT MATERIAL DESIGNATORS

- K = PCTFE (KEL-F®)
- V = VESPEL®
- P = PEEK™
- F = PFA / ASTM D3307, TYPE II

MATERIAL DESIGNATORS

- S = 316L SST SEMI F20
- A = 316L
- N = NICKEL 200
- M = NICKEL 400
- H = NICKEL ALLOY C22

CONNECTION TYPE DESIGNATORS

- FS = FEMALE FACE SEAL, SWIVEL
- MV = MALE FACE SEAL
- MS = MALE FACE SEAL, SWIVEL
- TS = TUBE STUB

PURITY DESIGNATORS

- S = STANDARD FINISH
- H = HIGH PURITY
- U = ULTRA-HIGH PURITY

NOTES:  
1. DRAWINGS FOR SPECIFICATION PURPOSES AND ARE FOR REFERENCE ONLY.  
2. ALL VERSIONS OF THE DRAWING ARE SUPERSEDED BY THIS RELEASE AND SUBJECT TO CHANGE WITHOUT NOTIFICATION.  
3. FOR M PORT CONFIGURATION, DISTANCE FROM BOTTOM SURFACE IS TYPICAL SHOWN FROM EDGE.

EFFECTIVE DATE: 12/11/2018	 1003 INDUSTRIAL DRIVE SAUK RAPIDS, MN 56379 VOICE: 320-251-0390 FAX: 320-251-5810
INTERPRET DRAWING PER: ASME Y14.5-2009	
THIRD ANGLE PROJECTION:	
PROPRIETARY AND CONFIDENTIAL THE INFORMATION CONTAINED IN THIS DRAWING IS THE SOLE PROPERTY OF TALON INNOVATIONS, INC. ANY REPRODUCTION IN PART OR AS A WHOLE WITHOUT THE WRITTEN PERMISSION OF TALON INNOVATIONS, INC. IS PROHIBITED.	DESCRIPTION: <b>CONVENTIONAL DIAPHRAGM VALVE, 1/4" HYBRID LOTO</b>
DO NOT SCALE DRAWING	SIZE: <b>C</b> SCALE: 3:2 PART NUMBER: <b>CDV4X-XXXXXXXX-07XXX</b> SHEET 1 OF 1